

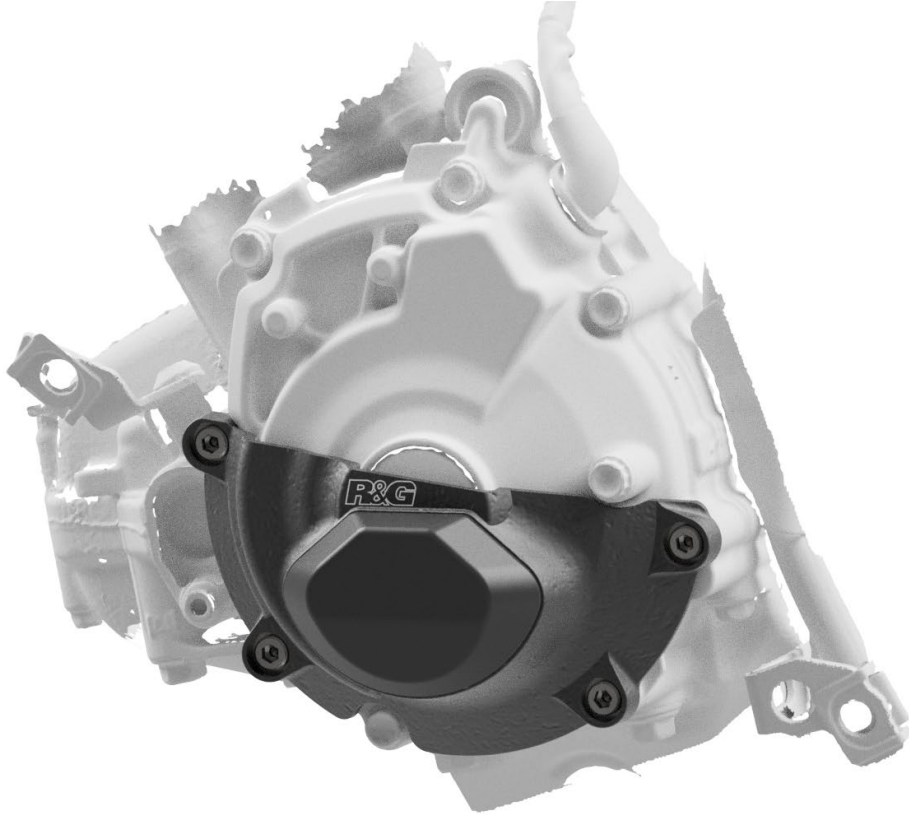

**FITTING INSTRUCTIONS FOR ECC0400PRO**  
**LHS ENGINE CASE COVER**



**THIS KIT CONTAINS THE ITEMS PICTURED AND LABELLED OVER PAGE.**  
SOME PARTS MAY BE SHOWN FOR CLARITY OF INSTRUCTIONS ONLY.

DO NOT PROCEED UNTIL YOU ARE SURE ALL PARTS ARE PRESENT.

**PLEASE READ ALL INSTRUCTIONS BEFORE PROCEEDING.**

**IF IN ANY DOUBT WHEN FITTING OUR PRODUCTS, CONSULT ONE OF OUR DEALERS  
OR HAVE FITTED BY A QUALIFIED TECHNICIAN.**

**PLEASE BE AWARE THAT THE PLASTIC SKIDDER IS ASSEMBLED IN POSITION FOR PACKAGING  
PURPOSES ONLY. YOU WILL NEED TO REMOVE IT, PLACE 1 DROP OF BLUE THREAD LOCK TO  
EACH BOLT AND REASSEMBLE ONTO THE ALUMINIUM ENGINE CASE COVER. DO NOT EXCEED  
15NM OF TORQUE.**

**DIGITAL COPIES OF THESE INSTRUCTIONS ARE AVAILABLE FROM:**

[WWW.RG-RACING.COM](http://WWW.RG-RACING.COM)

R&G  
Unit 1, Shelley's Lane, East Worldham, Alton, Hampshire, GU34 3AQ  
Tel: +44 (0)1420 89007 Fax: +44 (0)1420 87301 [www.rg-racing.com](http://www.rg-racing.com) Email: [info@rg-racing.com](mailto:info@rg-racing.com)



<b><u>TOOLS REQUIRED</u></b>	<b><u>GENERAL TORQUE SETTINGS</u></b>
<ul style="list-style-type: none"> <li>• Set of Metric Allen keys.</li> <li>• Metric Socket set.</li> <li>• Suitable Torque Wrench.</li> </ul>	M4 BOLT = 8Nm M5 BOLT = 12Nm M6 BOLT = 15Nm M8 BOLT = 20Nm M10 BOLT = 40Nm M12 BOLT = 40Nm

### **LEGEND**

<b>ITEM NO.</b>	<b>DESCRIPTION</b>	<b>QTY</b>
ITEM 1	CECC0400PRO (R&G ALUMINIUM ENGINE CASE COVER)	1
ITEM 2	ECS0183 (SKIDDER ASSEMBLY)	1
ITEM 3	M6 x 1.00 x 30mm CAP HEAD BOLTS	4
ITEM 4	M6 x 12mm O/D WASHER	4
ITEM 5	M5 x 0.80 x 12mm CSK BOLTS	4

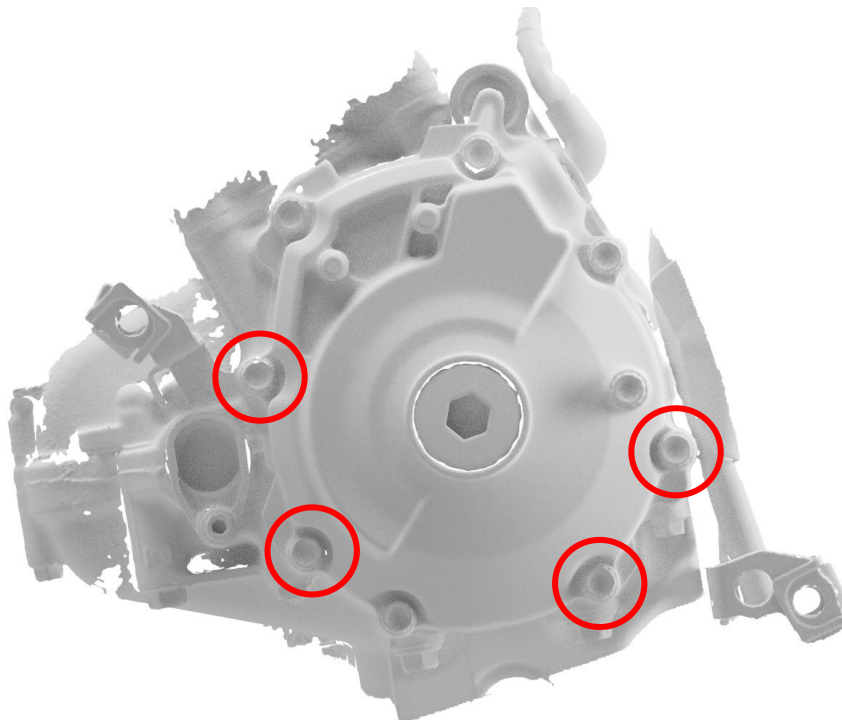

**PICTURE 1**



### **FITTING INSTRUCTIONS**

- Please make sure the engine is cold before proceeding with the fitting of the R&G cover.
- Affix the skidder (**ITEM 2**) to the Case cover (**ITEM 1**) using the M5 bolts (**ITEM 5**), ensuring the bolts are torqued to spec shown on page 2.
- Remove the OEM engine case bolts as highlighted in **PICTURE 1**. DO NOT REMOVE ALL OF THE CASE BOLTS.
- Place an M6 washer (**Item 4**) over each of the provided bolts.
- Use the 4x M6 bolts (**Item 3**) provided to secure the engine case cover to the case.
- With a socket wrench tighten the bolts equally so that they pull the cover into place. DO NOT FULLY TIGHTEN.
- Finally use a torque wrench set at 10 N/m (7 Lb/ft) to fully tighten.
- It is suggested that you check the tightness of the mounting bolts on a regular basis such as when cleaning or once a month.
- R&G will accept no liability if the above procedure and torque settings are not followed.

### **SKIDDER REPLACEMENT**

If your skidder is showing signs of wear and needs replacing, please follow the following steps:

- Remove the 4 x CSK bolts (**Item 5**) from the reverse side of engine case cover, this will allow the skidder to be separated from the engine case cover.
- Slot the replacement skidder into the skidder shaped recess on the front of the engine case cover and secure using 4 x CSK bolts supplied with the replacement skidder.

ISSUE 3 - 24/10/2024 (MH)

### **CONSUMER NOTICE**

The catalogue description and any exhibition of samples are only broad indications of the Products and R&G may make design changes which do not diminish their performance or visual appeal and supplying them in such state shall conform to the order. The Buyer acknowledges no representation or warranty (other than as to title) has been given or will apply to the Products other than those in R&G's order or confirmation and the Buyer confirms it has chosen the Products as being of merchantable quality and suitable for its particular purposes. Where R&G fits the Products or undertakes other services it shall exercise reasonable skill and care and rectify any fault free of charge unless the workmanship has been disturbed. The Buyer is responsible for ensuring that the warranty on the motorcycle is not affected by the fitting of the Products. On return of any defective Products R&G shall at its option either supply a replacement or refund the purchase money but shall not be liable if the Products have been modified or used or maintained otherwise than in accordance with R&G's or manufacturer's instructions and good engineering practice or if the defect arises from accident or neglect. Other than identified above and subject to R&G not limiting its liability for causing death and personal injury, it shall not be liable for indirect or consequential loss and otherwise its liability shall be limited to the amounts paid by the Buyer for the Products or the fitting or service concerned. These terms do not affect the Buyer's statutory rights.

### **R&G RETURNS POLICY (NON-FAULTY GOODS)**

Returns must be pre-authorized (if not pre-authorized the return will be rejected). Goods may only be returned direct to us if they were purchased direct from us (customer must prove if necessary). Otherwise to be returned to original vendor. Goods must be in re-sellable condition, in the opinion of R&G. All returns are subject to a 25% restocking and handling fee (25% of the gross value exc. P&P - at the prevailing price at time of purchase). The customer must pay any and all carriage charges. No returns of discontinued products, unless within 14 days of purchase. This policy does not affect your statutory rights and does not refer to faulty goods.

R&G

Unit 1, Shelley's Lane, East Worldham, Alton, Hampshire, GU34 3AQ

Tel: +44 (0)1420 89007 Fax: +44 (0)1420 87301 [www.rg-racing.com](http://www.rg-racing.com) Email: [info@rg-racing.com](mailto:info@rg-racing.com)



**NOTICE DE MONTAGE POUR ECC0400PRO**  
**COUVERCLE DE CARTER MOTEUR CÔTÉ GAUCHE**

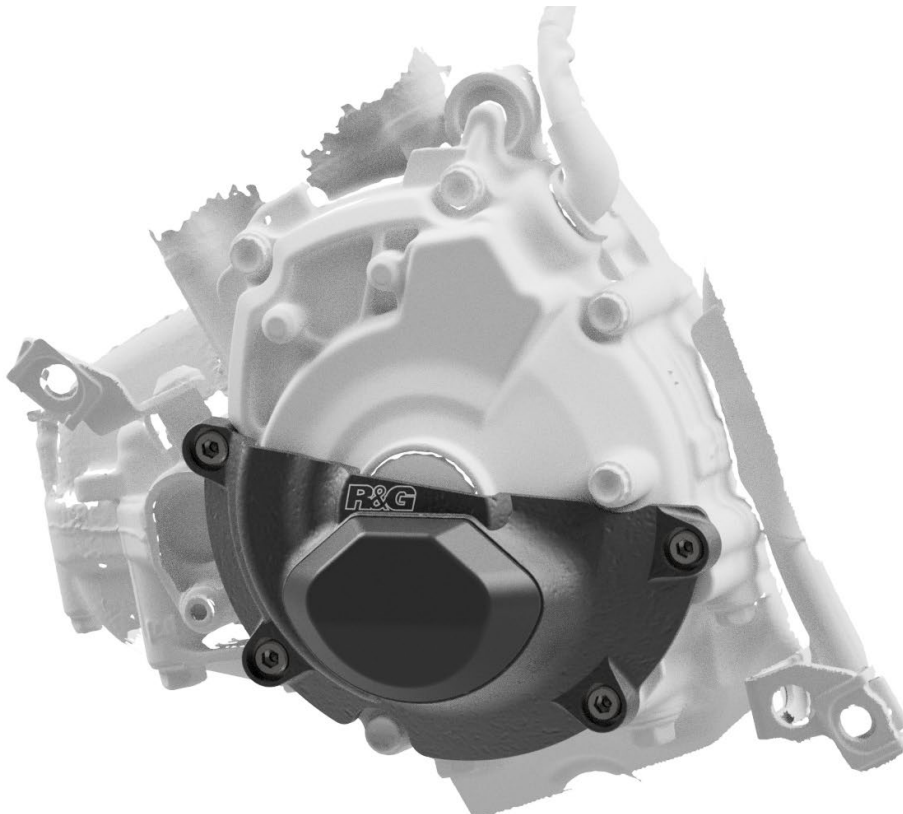

**CE KIT CONTIENT LES ARTICLES ILLUSTRÉS ET ÉTIQUETES SUR LA PAGE.**  
CERTAINES PARTIES PEUVENT ÊTRE PRÉSENTES UNIQUEMENT POUR LA CLARTÉ DES INSTRUCTIONS.  
NE PAS PROCÉDER AU MONTAGE TANT QUE VOUS N'ÊTES PAS SÛR QUE TOUTES LES PIÈCES SOIENT  
PRÉSENTES.

**VEUILLEZ LIRE TOUTES LES INSTRUCTIONS AVANT DE CONTINUER.**  
**EN CAS DE DOUTE LORS DU MONTAGE DE NOS PRODUITS, CONSULTEZ UN DE NOS**  
**REVENDEURS OU FAITES APPEL À UN TECHNICIEN QUALIFIÉ.**

**VEUILLEZ NOTER QUE LE CACHE DE PROTECTION EN PLASTIQUE EST UNIQUEMENT**  
**ASSEMBLÉ POUR L'EMBALLAGE. VOUS DEVREZ LE RETIRER, PLACER 1 GOUTTE DE FREIN**  
**FILET SUR CHAQUE BOULON ET LE REMONTER SUR LE COUVERCLE DU CARTER MOTEUR**  
**EN ALUMINIUM. NE PAS DÉPASSER 15 NM DE COUPLE.**

**NOTICE DISPONIBLE AU TÉLÉCHARGEMENT SUR :**  
[WWW.RG-RACING.COM](http://WWW.RG-RACING.COM)



<b><u>OUTILS REQUIS</u></b>	<b><u>VALEURS DE SERRAGE</u></b>
<ul style="list-style-type: none"> <li>• Clés Allen.</li> <li>• Clé métrique.</li> <li>• Clé dynamométrique.</li> </ul>	<p>M4 BOULON = 8Nm</p> <p>M5 BOULON = 12Nm</p> <p>M6 BOULON = 15Nm</p> <p>M8 BOULON = 20Nm</p> <p>M10 BOULON = 40Nm</p> <p>M12 BOULON = 40Nm</p>

## **LÉGENDE**

<b>ARTICLE NO.</b>	<b>DESCRIPTION</b>	<b>QTÉ</b>
ARTICLE 1	CECC0400PRO (PROTECTION CARTER MOTEUR R&G EN ALUMINIUM)	1
ARTICLE 2	ECS0183 (CACHE DE PROTECTION)	1
ARTICLE 3	M6 x 1.00 x 30mm BOULONS	4
ARTICLE 4	M6 x 12mm RONDELLE	4
ARTICLE 5	M5 x 0.80 x 12mm CSK BOULONS	4

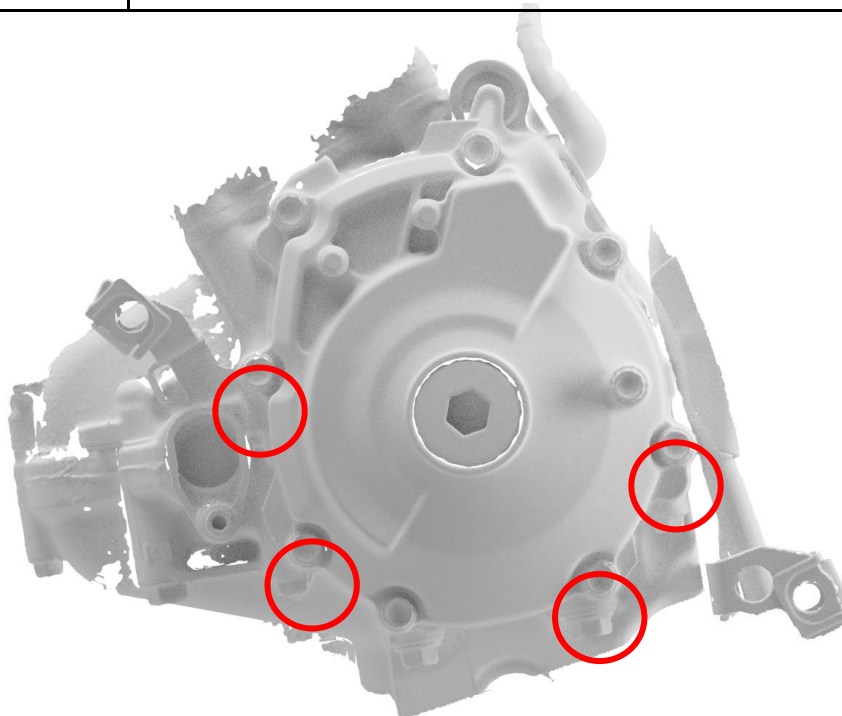

**PHOTO 1**



### **NOTICE DE MONTAGE**

- Assurez-vous que le moteur soit froid avant de procéder à l'installation du couvercle R&G.
- Fixez le cache de protection (ARTICLE 2) au couvercle du boîtier (ARTICLE 1) à l'aide des boulons M5 (ARTICLE 5), en vous assurant que les boulons soient serrés conformément aux spécifications indiquées à la page 2.
- Retirez les boulons du boîtier du moteur d'origine comme indiqué sur la PHOTO 1. **NE RETIREZ PAS TOUS LES BOULONS DU BOÎTIER.**
- Placez une rondelle M6 (article 4) sur chacun des boulons fournis.
- Utilisez les 4 boulons M6 (article 3) fournis pour fixer le couvercle du boîtier moteur au boîtier.
- À l'aide d'une clé à douille, serrez les boulons de manière égale afin qu'ils tirent le couvercle en place. **NE SERREZ PAS COMPLÈTEMENT.**
- Enfin, utilisez une clé dynamométrique réglée à 10 N/m (7 Lb/ft) pour serrer complètement.
- Il est suggéré de vérifier régulièrement le serrage des boulons de montage, par exemple lors du nettoyage ou une fois par mois.
- R&G n'acceptera aucune responsabilité si la procédure ci-dessus et les réglages de couple ne sont pas suivis.

### **CACHE DE RECHANGE**

Si votre cache de protection montre des signes d'usure et doit être remplacé, veuillez suivre les étapes suivantes :

- Retirez les 4 boulons (article 5) de l'arrière du couvercle du carter moteur, cela permettra de séparer le cache de la protection carter moteur.
- Insérez le cache de rechange dans le renforcement en forme de cache à l'avant du couvercle de protection carter moteur et fixez-le à l'aide des 4 boulons fournis avec le cache de remplacement.

ISSUE 3 – 24/10/2024 (MH)

### **CONSUMER NOTICE**

The catalogue description and any exhibition of samples are only broad indications of the Products and R&G may make design changes which do not diminish their performance or visual appeal and supplying them in such state shall conform to the order. The Buyer acknowledges no representation or warranty (other than as to title) has been given or will apply to the Products other than those in R&G's order or confirmation and the Buyer confirms it has chosen the Products as being of merchantable quality and suitable for its particular purposes. Where R&G fits the Products or undertakes other services it shall exercise reasonable skill and care and rectify any fault free of charge unless the workmanship has been disturbed. The Buyer is responsible for ensuring that the warranty on the motorcycle is not affected by the fitting of the Products. On return of any defective Products R&G shall at its option either supply a replacement or refund the purchase money but shall not be liable if the Products have been modified or used or maintained otherwise than in accordance with R&G's or manufacturer's instructions and good engineering practice or if the defect arises from accident or neglect. Other than identified above and subject to R&G not limiting its liability for causing death and personal injury, it shall not be liable for indirect or consequential loss and otherwise its liability shall be limited to the amounts paid by the Buyer for the Products or the fitting or service concerned. These terms do not affect the Buyer's statutory rights.

### **R&G RETURNS POLICY (NON-FAULTY GOODS)**

Returns must be pre-authorized (if not pre-authorized the return will be rejected). Goods may only be returned direct to us if they were purchased direct from us (customer must prove if necessary). Otherwise to be returned to original vendor. Goods must be in re-sellable condition, in the opinion of R&G. All returns are subject to a 25% restocking and handling fee (25% of the gross value exc. P&P – at the prevailing price at time of purchase). The customer must pay any and all carriage charges. No returns of discontinued products, unless within 14 days of purchase. This policy does not affect your statutory rights and does not refer to faulty goods.

R&G

Unit 1, Shelley's Lane, East Worldham, Alton, Hampshire, GU34 3AQ

Tel: +44 (0)1420 89007 Fax: +44 (0)1420 87301 [www.rg-racing.com](http://www.rg-racing.com) Email: [info@rg-racing.com](mailto:info@rg-racing.com)